

# Shut-off damper with motor shelf

# DTH1U

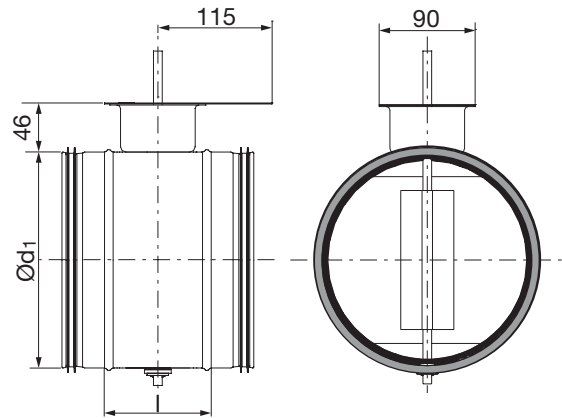

## Dimensions



## Description

Shut-off damper with motor shelf HYLLA LMNM. Consists of a DTU damper with motor shelf HYLLA LMNM added.

The damper is designed to have a motor added on site.

There is a separate assembly, measuring, balancing and maintenance instruction for this product.

Ø 80–315 fullfills pressure class C in closed position.

Ø 400–500 fullfills pressure class B in closed position.

## Motorizing

See separate motorizing table.

The torque needed for motorizing is given in the adjacent table.

Ød <sub>1</sub> nom	l [mm]	M Nm	m [kg]	Sealing class past closed blade
80	100	2,0	0,70	4
100	100	2,0	0,75	4
125	100	2,0	0,90	4
160	100	2,0	1,10	4
180	100	2,0	1,20	4
200	100	2,0	1,40	4
250	100	3,0	1,90	4
315	100	4,0	2,50	4
400	100	8,0	4,00	4
500	115	10	6,50	4

## Technical data

For technical data go to [LindQST](#).

## Ordering example

