

Bend – long

BSU 90°

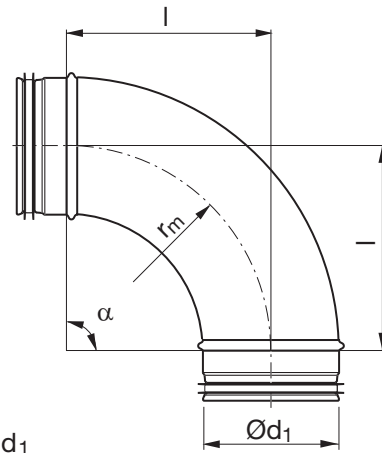

Dimensions



$r_m \approx 1,5 \cdot d_1$

Ød ₁ nom	l [mm]	m [kg]
100	150	0,50
150	225	0,95
160	240	1,14

Description

Pressed and seam welded bend.

Technical data

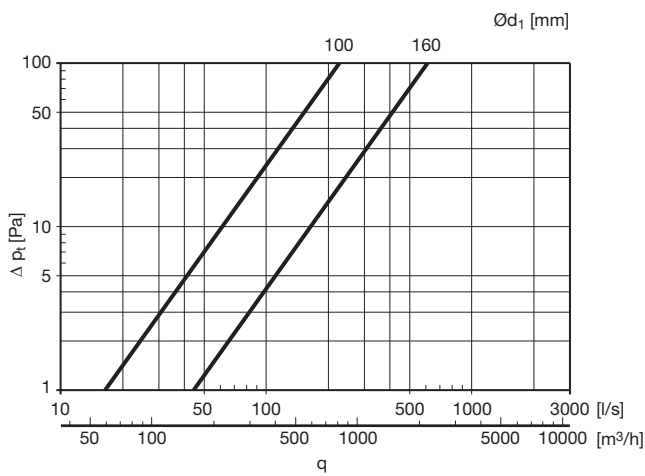

Ordering example

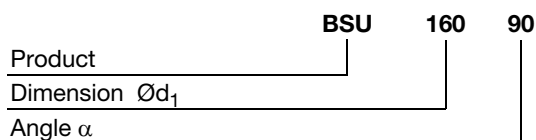

Bend – long

BSU 45°



Description

Pressed and seam welded bend.

Technical data

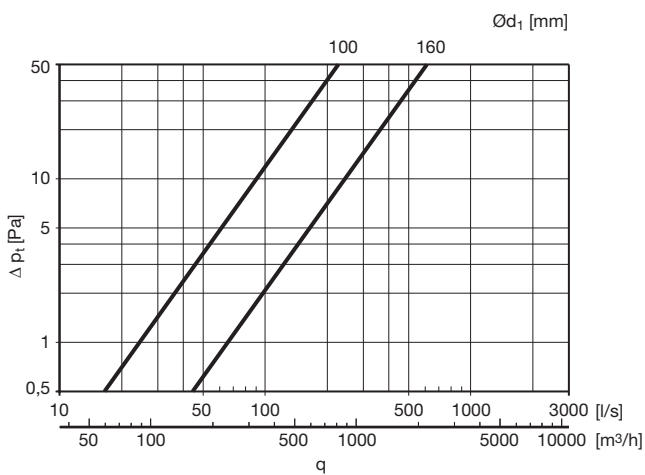

Dimensions

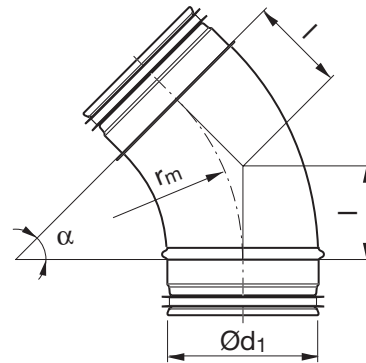

$$r_m \approx 1,5 \cdot d_1$$

$\text{Ø}d_1$ nom	l [mm]	m [kg]
100	62	0,26
150	93	0,49
160	100	0,59